

AFB501 BOX

The Spider 8 Gang Access Floor Box (AFB-501) is where agility in your power system becomes a reality. As the access point for the user, the AFB-501 integrates power, voice-data and audio-visual connections in an easily installed, modular design.

Initial requirements and future demands are easily met by the AFB-501. Its ample room delivers the utilities in various configurations and the square base design frees you to turn it in any direction to better suit your needs. 'Plug and Play' power connects with an 'extra-flex' whip, allowing the AFB-501 to be installed in any orientation. The Spider patented 'Quick-in' system anchors each box to the raised floor panel in seconds (Spider 8 Gang Access Floor provides modular agility in raised access floors 5" or higher.)

Available with a male or female whip, compatible with either 4-circuit or 3-circuit with up to a 8-wire configuration.



Integrates with:



quadra
NET



spider
NET

GENERAL SPECIFICATIONS

- 20 Amp 120V/208Y 60Hz
- Available empty or pre-wired with a 15" whip and quick connect end (shown above)
- Access Floor Box provided with hinged lid and cord exit hatch
 - Available in:
 - 5" (127mm) deep 8 gang
- 16 gauge galvanized steel construction
- Spider's Patented "QUICK IN" no assembly required installation
- Durable black or granite power coat finish on lid and trim ring
 - Also available in brass and aluminum color
- Reversible hinged lid – carpet inlay one side (carpet by others), black or granite powdercoat finish other side
 - Also available in brass and aluminum color
- Pop-up lid handle – acts as a wire/cable entry point
- Faceplates (Black, gray, ivory, white) supplied and installed by Spider
- Specify data face plates when data is specified otherwise the ports will come with a blank cover plate
- Connectors (if specified) have color coded tags and polarity keys to prevent interconnection of 3 and 4 circuit components

LISTINGS

- UL listed. Manufactured wiring system per UL 183.
- UL listed. Metallic Outlet Boxes per UL 514a.
- CSA Certified to CSA standard C2.2 No 203-M

APPLICABLE CODES

- Access Floor boxes must be installed in accordance with the NEC, CEC and local electrical codes.

BOX DIMENSIONS & SPECIFICATIONS

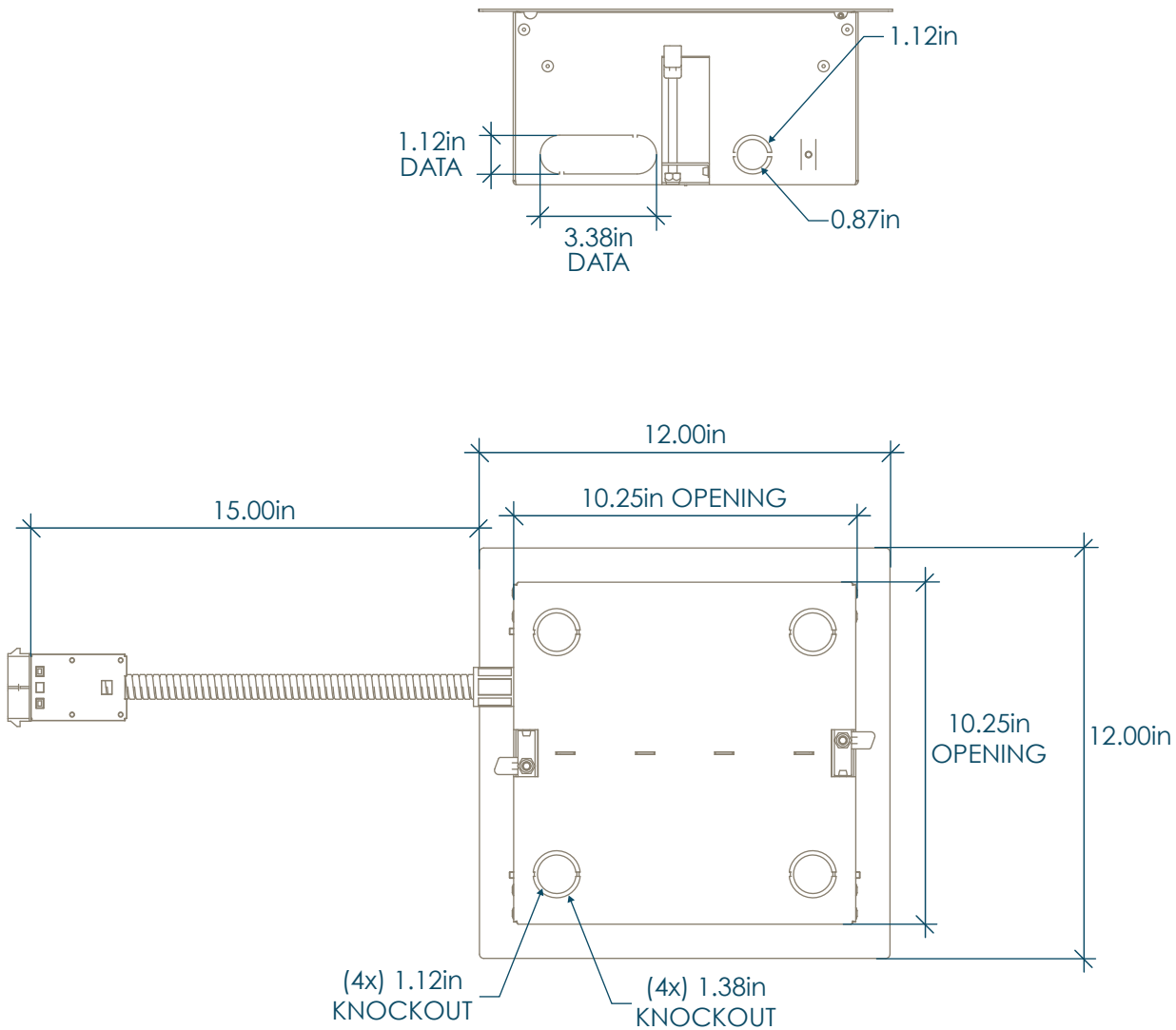

AFB 501

1 - 15" (356mm) whips w/ male or female Quick-connect plugs

Available in 3 circuit or 4 circuit Systems or configured to meet job-specific conditions